

Aluminium ANODE ZC55-8

gross weight: 10,60 kg
nett weight: 8,00 kg

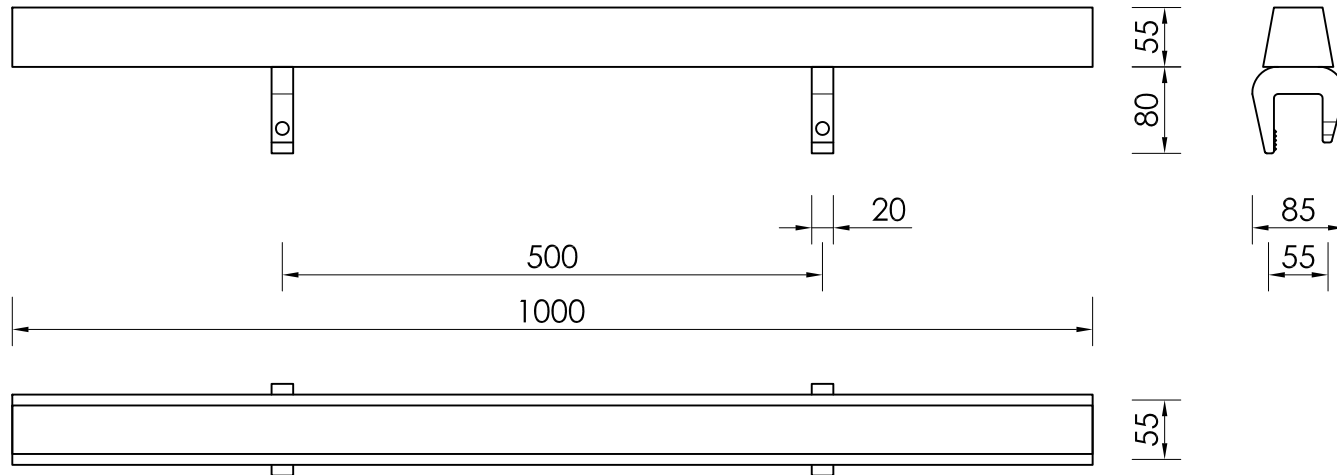

Technical specification AlZnIn - alloy type A2 according to EN12496:2013 :

Alloying elements:		Impurities:	
Zn [%]:	3,0 - 5,5	Fe [%]:	max 0,09
In [%]:	0,016 - 0,040	Cu [%]:	max 0,005
Al -	balance	Si [%]:	max 0,10

Electrochemical efficiency min: 2500 Ah/kg
according to DNV RP B401 test appendix B

Note:

- All weights and dimensions are nominal.
- Dimensions in mm

 MAKROMOR CATHODIC PROTECTION	MAKROMOR SP. Z O.O. Ul. Gołębia 15 81-185 Gdynia, POLAND Phone: +48 58 661-57-99 Fax: +48 58 661-01-89 e-mail: biuro@makromor.pl website: www.makromor.pl		Scale:	1:7,5
	Type: ALUMINIUM TANK ANODE ZC55-8		Insert type:	S235JR
Product code: A106/ZC55/55/55/1000/500/0		Alloy:	AlZnIn	
Drawer: Ewa Nawrocka	Date: 17-04-2013	Approved: Grzegorz Pryłowski	Alternative type:	
Copyright MAKROMOR SP. Z O.O. All rights reserved.			Drawing No.:	AZC558/0
			Date:	18-04-2013